

Area 150,9 X 60,5 must be interchangeable inserts in the tool and the area polished to Ra 0,1µm

All other outer surfaces : Charmilles 28 (Ra 2,5µm)

SECTION A-A

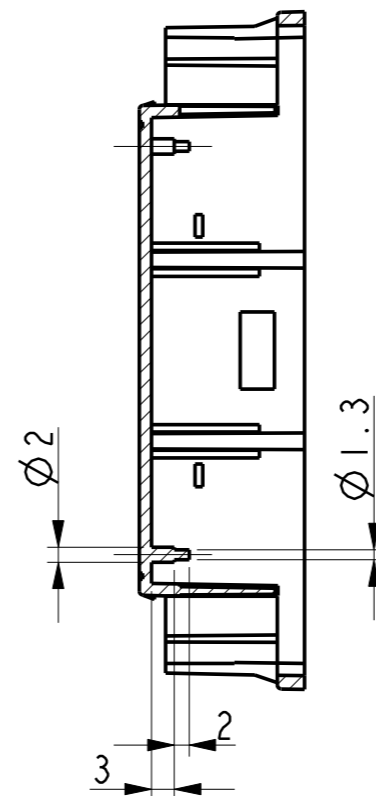

SECTION B-B

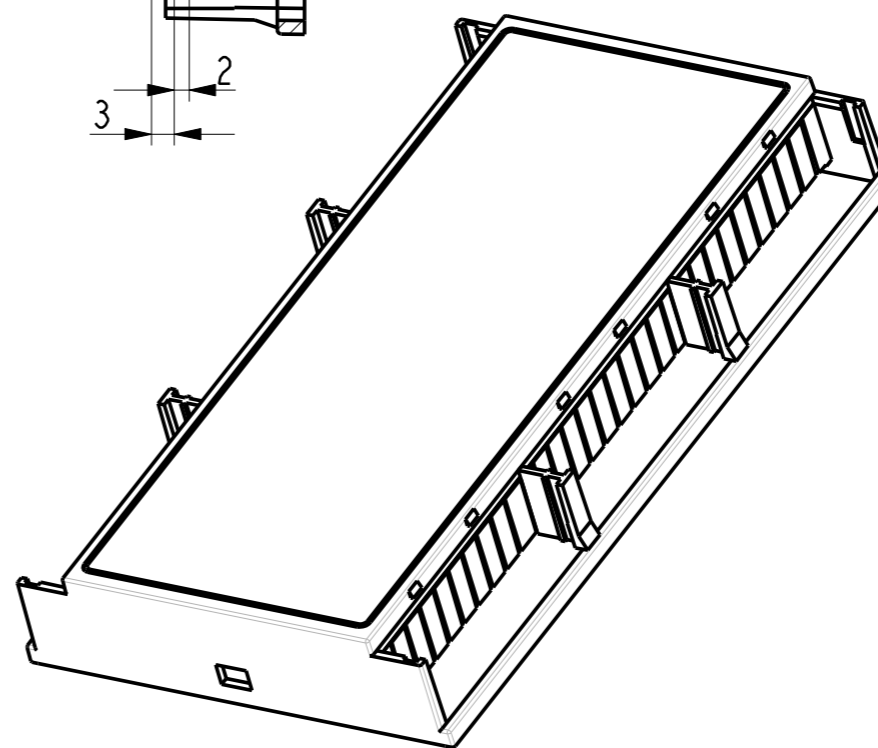
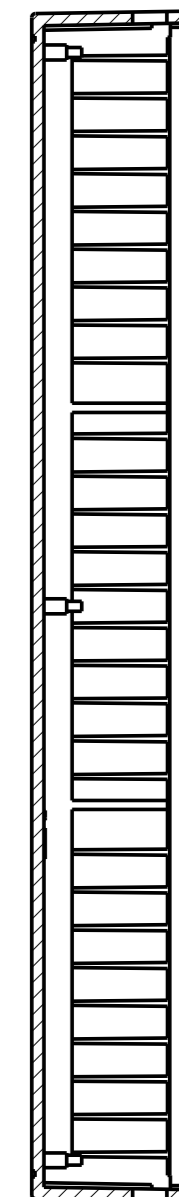

SCALE 0.750

Gesp.: h:\Industriegehäuse\Hutschienengehäuse\SerieLP\Zeichnungen\Wöhr\GH02HS02\035\510.cdr	
Freimasstoleranzen nach DIN 7168 mittel	
Verw. / Kd. Nr. Siebdruck /	
A	Maßstab
Ausgabe	Gez.: Datum/Name Gepr.: Datum/Name
BEZEICHNUNG GH02HS02/157/510	
Zeich.-Nr.:	
Artikel-Nr.: Serie LP	
RICHARD WÖHR GMBH Gräfenau 58-60 D-75339 Höfen / Enz Telefon (07081) 9540-0 Telefax (07081) 9540-90 Richard@WoehrGmbH.de www.WoehrGmbH.de	